

GS2.56-HV Series

— Operation manual —

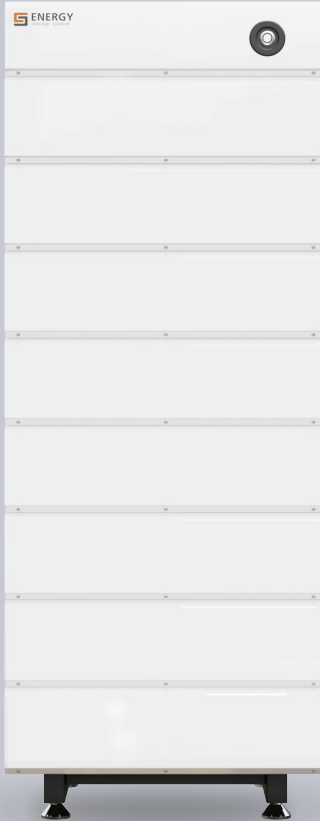

Stackable



Easy to install



Single phase/three phase available



Emergency backup power



Cost effective

Foreword

Thank you for choosing the products of GS(Ningbo)ESS technology Co.,Ltd! In order to ensure your legitimate rights and interests, safe and use our product correctly, please read the user manual before installation and commissioning.

Disclaimer

- This user manual contains a series of contents such as installation, operation methods, common troubleshooting and technical indicators. When installing, using, or maintaining the product, you must read this chapter carefully and follow the safety precautions specified in this chapter. we don't take responsibility for any injury or loss caused by illegal operation;
- Please keep the operation manual properly for future reference;
- The contents of the manual will be continuously updated, corrected and upgraded. If it does not conform to the actual product, please refer to the actual product you purchased, or obtain the latest version of the manual through the sales channel.

Version	Date	Records
V1.0	2024.1.29	Initial Release

Contents

1. Safety notes.....	4
2. Product introduction.....	5
2.1 Product introduction.....	5
2.2 Logo description.....	5
2.3 Battery system introduction.....	6
2.4 Control box introduction.....	6
2.5 Battery introduction.....	7
2.6 Technical parameters.....	8
3. Product storage and packaging.....	9
3.1 Product storage environment.....	9
3.2 Product packaging information.....	9
4. Product installation.....	11
4.1 Install the environment.....	11
4.2 Install gaps.....	11
4.3 Install tools.....	12
4.4 Product installation.....	13
4.5 Electrical connections.....	14
5. System operation.....	19
5.1 Check before powering on.....	19
5.2 Power on the system.....	19
5.3 Indicators.....	19
5.4 Powering off the system.....	20
5.5 WIFI Configuration.....	21
6. Maintain the system.....	25

1 Safety Notice

DANGER!

- The battery system is a high voltage system, please turn off the power before operating the equipment in the system, so as to avoid danger!
- Wiring work must be carried out by qualified electrical engineers, otherwise there is a risk of electric shock or damage to the system!
- Do not touch live parts or DC cables, which may cause electric shock and endanger your life!
- Before wiring, make sure that the power supply is disconnected, otherwise there is a risk of electric shock or fire!
- The installed cable must meet the requirements and the distribution part must comply with safety codes!
- During normal operation, do not directly open the shell of the machine, otherwise it will cause electric shock!
- After opening the shell, there is still residual power inside the machine, do not touch the exposed part of the line directly, so as not to cause electric shock!
- Maintenance and overhaul must be carried out by professional maintenance personnel in accordance with local regulations. Users should not disassemble the machine by themselves, which will cause electric shock and damage to the product!

WARNING!

- If the battery module leaks electrolyte, avoid contact with the leaking liquid or gas. Electrolyte is corrosive or it may cause skin inflammation and chemical burns.
If a person is exposed to a leaked substance:
Inhalation: Evacuate the contaminated area immediately and seek immediate medical attention!
Eye contact: Flush eyes with running water for 15 minutes and seek immediate medical attention!
Skin contact: Wash the affected area thoroughly with soap and water and seek immediate medical attention!
Ingestion: Induce vomiting, and seek immediate medical attention!
- This product in the process of handling, should avoid strong vibration, fall, bump, it is strictly prohibited to put the packing box upside down, unpacking and handling do not lose accessories and instructions, warranty card and so on!
Do not hit, pull, drag or step on the battery module!
Do not insert unrelated objects into any part of the battery module! Do not immerse the battery module in water or seawater! Do not contact with strong oxidants!
Do not short circuit the battery module!
Do not store the battery module at high temperatures (over 50 °C)! Do not store the battery module in direct sunlight!
Do not store the battery module in a high humidity environment!
Do not use the battery module if it is defective, or has cracks, breaks, and other damage that prevents it from working! And contact GS ESS after-sales service

CAUTION!





- Department within 48 hours!
- Unpacking inspection, if the product is found damaged or missing parts can not be installed, otherwise there may be a failure!
- When the packing list does not match the actual name, please do not install and contact the supplier in time!
- The risk of personal injury due to the weight of the battery module! Personal injury may occur if the battery module is improperly lifted or dropped during transportation or installation!
Handle and lift with care!
Wear appropriate personal protective equipment throughout the battery system's operation!
- If the battery is not installed within one month after receiving the battery, the battery should be charged to more than 50% SOC before maintenance can begin!

2 Product Introduction













2.1 Product description

- This document describes the product introduction, application scenarios, installation, commissioning, and maintenance of the GS2.56-HV high voltage energy storage battery system (battery system for short).
- The energy storage battery system is mainly composed of the BMC-S001 control box (hereinafter referred to as the "control box") and the RBS-S001 battery box (hereinafter referred to as the "battery").

Battery capacity expansion is as follows:

GS2.56-HV ×4	GS2.56-HV ×5	GS2.56-HV ×6	GS2.56-HV ×7	GS2.56-HV ×8
				

2.2 Label

Signs	Instructions	Signs	Instructions
	TUV Sud certified.		Keep away from children!
	Beware of electrocution!		Read the product instructions carefully before operating the equipment!
	The equipment is potentially dangerous after operation. When operating the equipment, pay attention to it Defend.		Do not dispose of the battery system with household waste, the installation site should be observed Applicable e-waste disposal regulations!
	Watch out for explosions!		CE certification marking.
	Batteries contain corrosive electrolytes! Avoid contact with leaking substances!		Equipment should be placed in the correct place and in accordance with local environmental regulations Recycle!
	Do not expose the battery to high temperatures, open flames!		Protective grounding mark, used to indicate where the PGND cable is connected.

2.3 Introduction

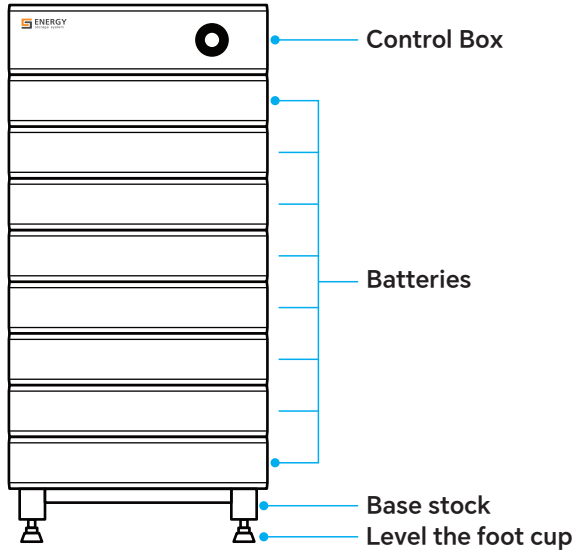

NOTICE!

- Up to 8 batteries and 1 control box can be installed per cluster battery system and up to 5 cluster battery systems can be connected in parallel.
- Make sure the control box is always mounted above the battery.
- This manual introduces the installation and wiring steps of the product with the configuration of 8 batteries as an example.

2.4 Control Box

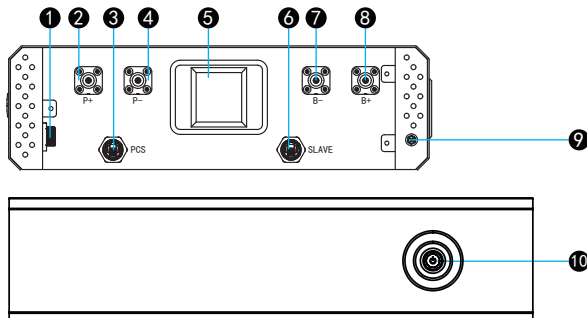



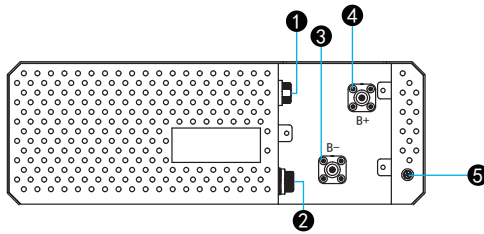

Serial number	Instructions
1	Cluster parallel port (B-COM)
2	Dc output (P+) to inverter BAT (+)
3	RJ45 - Interface (PCS)
4	Dc output (P-) to inverter BAT (-)
5	Air switch
6	RJ45 - Interface (SLAVE)
7	Dc input (B-) to battery (B-)
8	Dc input (B+) to battery (B+)
9	Ground interface
10	Dc switch

2.5 Battery



Serial number	Instructions
1	RJ45 - Interface 1
2	RJ45 - Interface 2
3	Dc connection (-)
4	Dc connection (+)
5	Ground interface

2.6 Technical

Model number					
Number of battery packs	4	5	6	7	8
Rated voltage (V)	204.8	256	307.2	358.4	409.6
Rated energy (kWh)	10.24	12.8	15.36	17.92	20.48
Usable energy (90% DOD) (kWh)	9.22	11.52	13.82	16.13	18.43
Dimensions (WxHxD) (mm)	535*755*425	535*900*425	535*1045*425	535*1190*425	535*1335*425
Weight (kg)	123	150	177	203	230
Voltage range (V)	166.4-232.32	208-290.4	249.6-348.48	291.2-406.56	332.8-464.64
Battery technology	Lithium iron phosphate				
IP rating	IP54				
Cooling method	Natural air cooling				
Rated charging/discharging current (A)	50				
Maximum continuous charge and discharge current (A)	50				
Operating Charge / Discharge temperature (°C)	0~ 50 / -10~ 50				
Environment humidity	≤95%RH (non- condensing)				
Cycle life(25°C, 0.2C, 90%DOD)	>6000times cycles				
Altitude conditions (m)	≤2000				
Certification	EN61000, IEC62619, IEC62477, IEC62040, UN38.3, UL, VDE2510-50				
Warranty (Years)	10				

3 Product storage and packaging

3.1 Product storage environment

If the device is not installed and used immediately after being unpacked, ensure that the storage environment meets the following conditions:

- If the device is not installed and used within 3 days after being unpacked, use the original packing case. If the original packaging is not available, please use cartons of the same specifications that meet the following requirements:
 - Load more than 40kg;
 - Fully enclosed
- Storage SOC: 25%~50%SOC, charge and discharge cycle every 3 months.
- Storage temperature range: 0°C~35°C.
- Humidity range: 0~90% no condensation.
- Equipment should be stored in a cool place, away from high temperatures and direct sunlight.
- Keep the device away from inflammable, explosive, and corrosive materials.
- Keep the device away from rain.

3.2 Product packaging information

Control box:

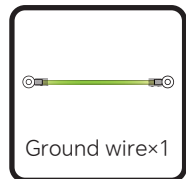
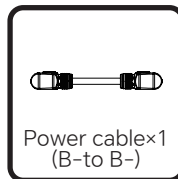
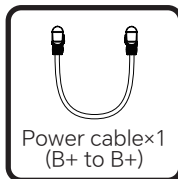
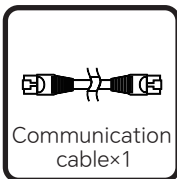
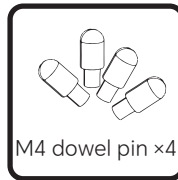
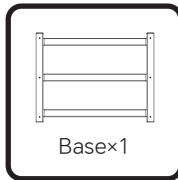

Battery:

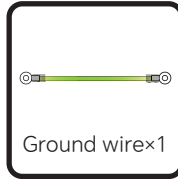
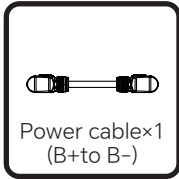
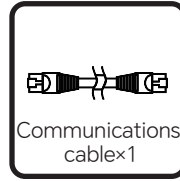

- Open the package, check whether the product has been deformed or damaged during transportation, and check the number and type of related accessories;
- Please read and save the product installation instructions carefully;
- It is recommended not to unpack the package until the unit arrives at the installation site.

4 Product Installation

4.1 Installation environment

- The battery system must be installed on a flat ground with sufficient load-bearing capacity; if the ground is not flat or does not have enough bearing capacity, it is necessary to ensure by other means (such as making another foundation, adding a bearing board, etc.)!
- The battery system works best in a temperature environment of 20~45 °C!
- Do not install in direct sunlight, rain environment!
- Do not install near high heat source or low temperature environment!
- Do not install in areas with extreme ambient temperature changes!
- Do not install in an environment with strong interference!
- Do not install in an area easily accessible to children!
- Do not install in areas prone to water accumulation!
- Do not place flammable and explosive items around the equipment!

4.2 Installation Gap

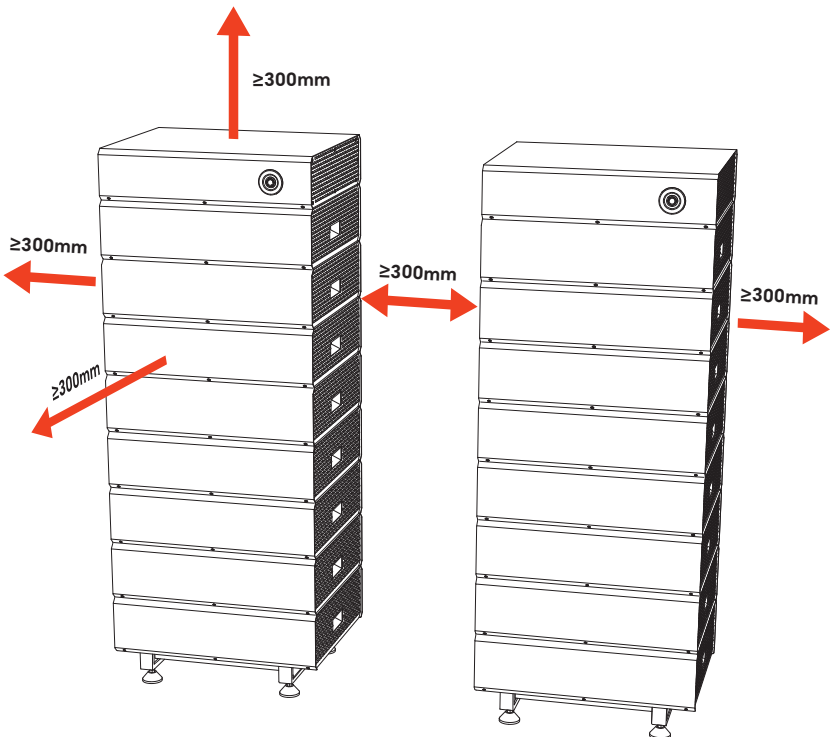

4.3 Installation tools

• To protect the safety of operators and installers, select and use appropriate tools and measuring instruments that are certified for accuracy.

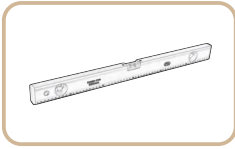

Levelling instrument

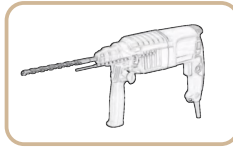

Drill



Hammer



Cordless brushless impact wrench kit

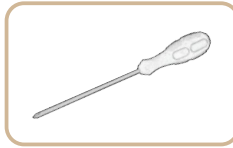

Screw driver

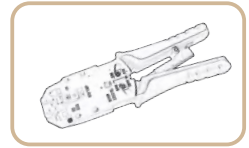

RJ45 crimp tool

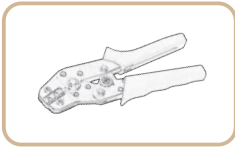

Crimpi plier



Multimeter



Pen

Note: The exact tools to use are subject to the actual situation on site.

• Batteries have voltage, please wear the appropriate arc flash safety suit (gloves, clothing and face mask) before installation.



Arc protection clothing



Insulation gloves



Goggles



Safety Shoes

• Noise may exceed the legal threshold (< 70dBA) during operation and appropriate ear protectors must be worn.

4.4 Product installation

NOTICE!

- The product has a certain weight, please handle it carefully when installing, so as to avoid injury and property damage caused by product falling!

1. Remove the battery, control box and base.
2. Attach the leveling foot cup to the bottom bracket and screw on the the dowel pins.
3. Align the positioning holes at the bottom of the battery with the positioning pins and stack them in turn (up to 8 layers for a single cluster battery).

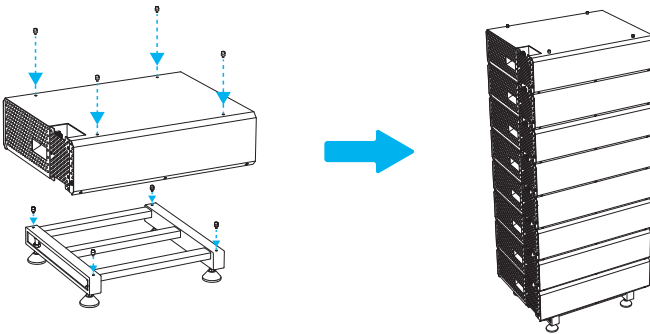

4. Stack the control box on top of the battery.

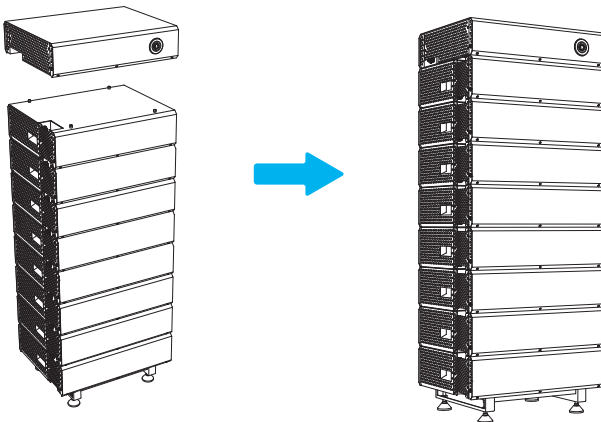

4.5 Electrical Links

NOTICE!

- When installing the device, you must first install the PGND cable; When removing the device, the PGND cable must be removed last!
- Protection ground conductor cross-sectional area: 6mm^2 . The wire must meet the outdoor use standard!

4.5.1 Ground connection

1. Take out the ground cable.

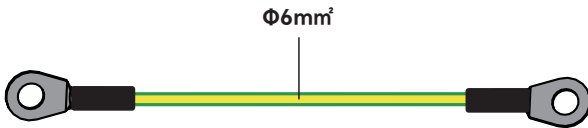

2. Unscrew the grounding hole with a screwdriver and connect the grounding wire to the battery and control box.

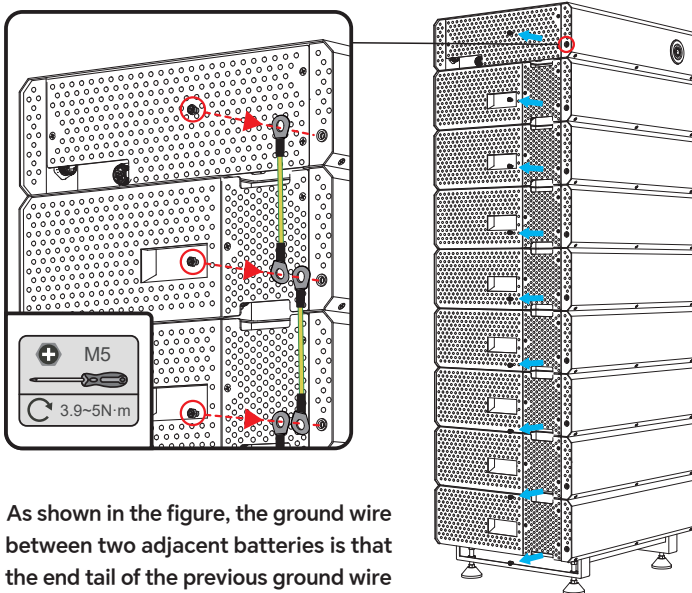

- As shown in the figure, the ground wire between two adjacent batteries is that the end tail of the previous ground wire and the head of the next ground wire are superimposed on the same ground wire hole and fixed with screws.

Schematic diagram of ground wire connection:

- The end ground wire should be connected to a reliable ground point.

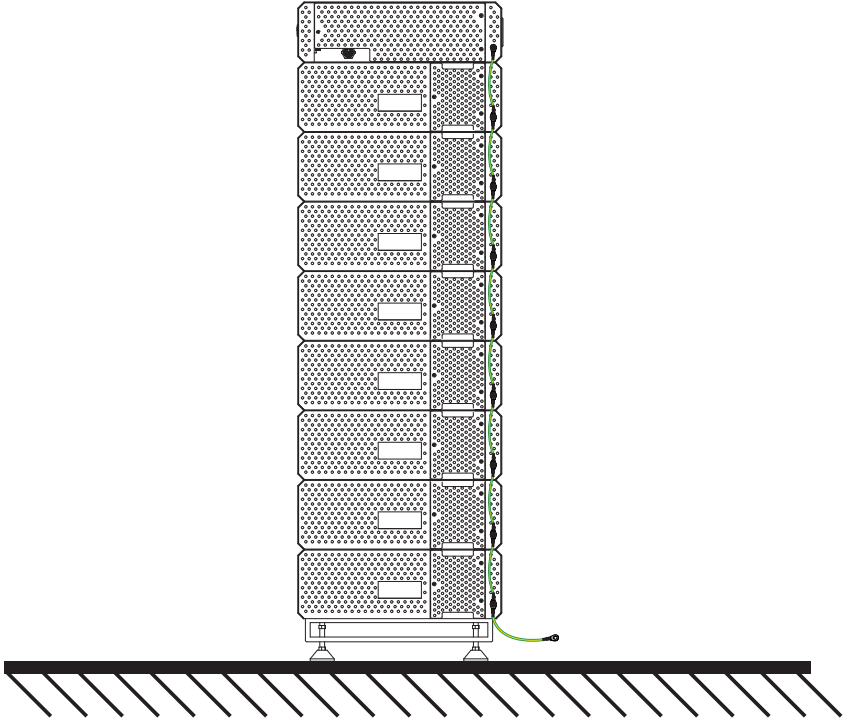
**4.5.2 Power Wire****NOTICE!**

- The power lines between batteries are connected in series, and the negative electrode of the battery is connected to the cathode of the next battery. The power cable between the control box and the battery is connected in parallel, the positive pole of the control box power cable is connected to the positive pole of the battery, and the negative pole is connected to the negative pole of the battery!
- There is no isolation switch in a single battery, do not short-circuit the positive and negative poles of the battery during installation!
- Battery system is a high-voltage system, before connecting power cable, please turn off the power, so as to avoid danger!
- Power cable conductor cross-sectional area: 16mm². The wire must meet the outdoor use standard!

1. Unscrew the cover plate and remove the cover plate of the control box and battery.

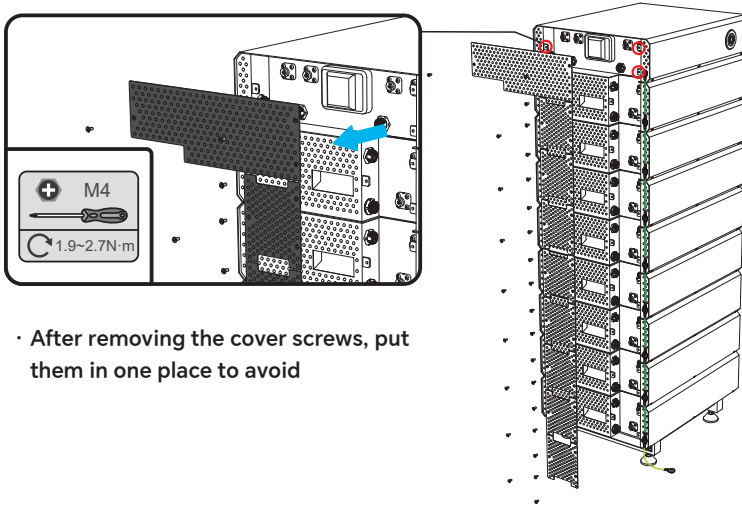

· After removing the cover screws, put them in one place to avoid

2. Take out the power

cable and communication cable.

Battery to battery (B+ to B-) :

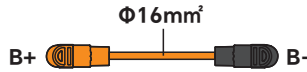

Battery with control box
(B- to B-) :



Battery and control
box (B+ to B+) :



Battery wiring diagram:

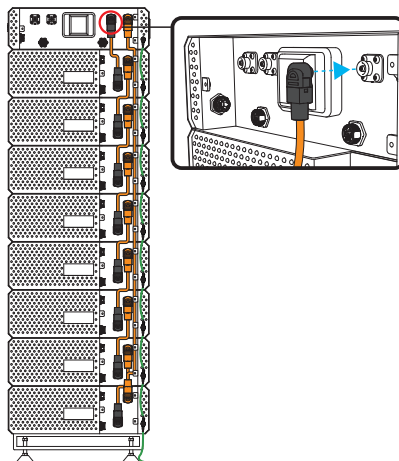

4.5.3 Communication cable connection

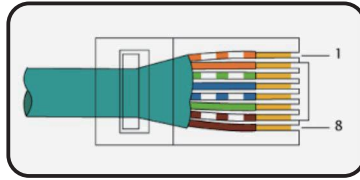

Pin	1	2	3	4	5	6	7	8
Features	NC	NC	NC	CANH	CANL	NC	NC	NC

Communication cable connection diagram:

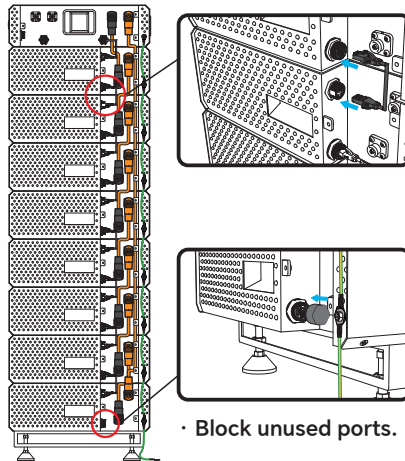

4.5.4 Inverter connection

Inverter connection diagram:

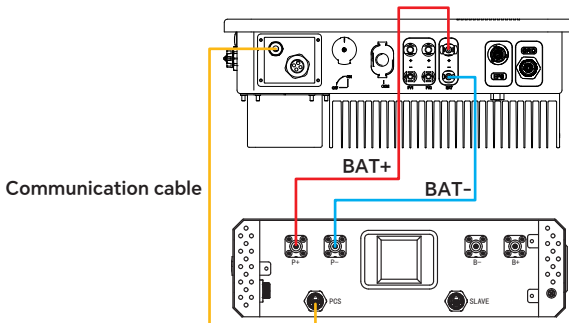

· The inverter shown in the figure is used as an example.
The connection ports refer to actual inverters

4.5.5 Multiple clusters in parallel

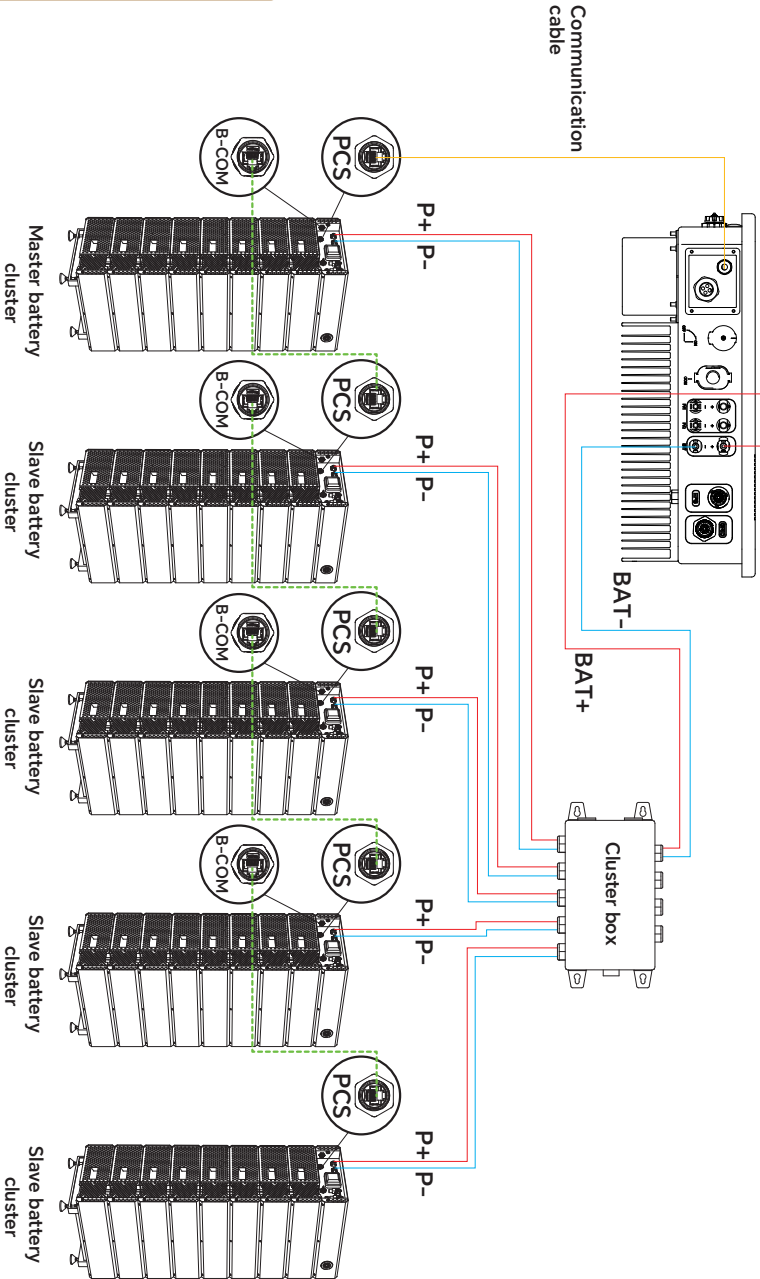

5 System operation

5.1 Check before power on

NOTICE!

When the battery system is powered on, be sure to check the following to prevent system damage:

- The device is firmly installed, the installation position is convenient for operation and maintenance, the installation space is convenient for ventilation and heat dissipation, and the installation environment is clean and tidy!
- Protect ground cable, power cable, communication cable, terminal resistance connection is correct and fasten!
- Cable binding line requirements, reasonable distribution, no damage!
- Unused port blocked!

5.2 Power on

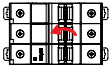
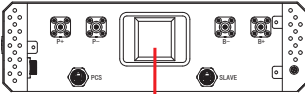

- Close the circuit breaker

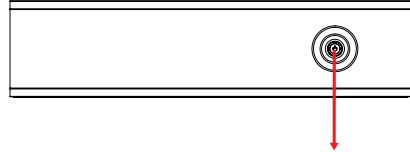

- Turn on the DC switch on the control box

5.3 Lights

NOTICE!

BMS light up Instructions:

- "0": Off; "1": Steady on;
- "Flash 1": On for 0.5S, off for 2.0S, and cycle.
- "Flash 2": On for 1.0S, off for 1.0S, and cycle.
- "Flash 3": On for 2.0S, off for 2.0S, and cycle.

Power display (control box) :

Indicator status	Instructions
Green light on	Power level: 100%
Yellow light on	Power level: 30%~60%
Red light on	Power level: <30%

Fault Display (BMS) :

Status	light bead	RUN	ARM
Power-off state		0	0
Power on and run without any faults		1	0
There is a non-forbidden charge or there is a non-forbidden fault		1	Flash 1
Only no charge fault, but no break relay fault		1	Flash 2
Only off fault, but no break relay fault		1	Flash 3
At the same time, there are no charging and discharging faults, but no relay fault		1	1
Only no charge fault, and there is a broken relay fault		0	Flash 2
No off fault only, with broken relay fault		0	Flash 3
At the same time there is no charge, no discharge fault, and break relay fault		0	1

5.4 Power down the system

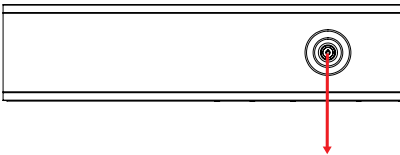

- Turn off the DC switch on the control box

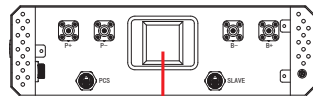

- Disconnect the circuit breaker

5.5 WIFI Configuration

1. Switch on Power Button, wait until signal lights turn **GREEN**.

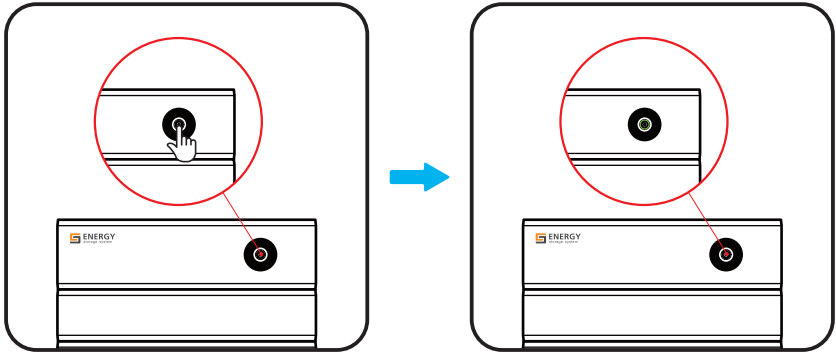

2. Scan QR Code label via your mobile phone, download “**GS ENERGY**” on Apple Store or Google Play.

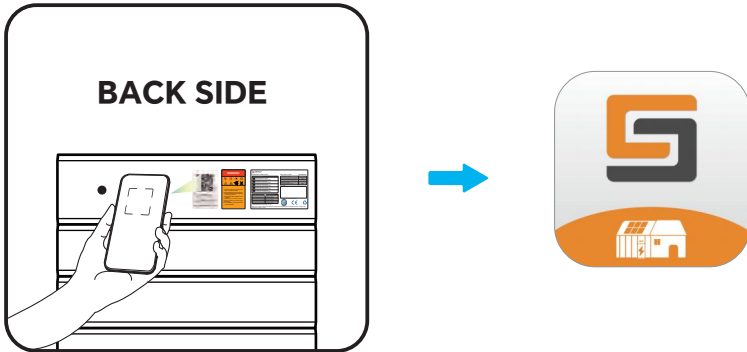

3. Turn on Bluetooth and Wireless Network on mobile phone.



ON



ON

4. Click APP icon, user can choose to either Register or Login.

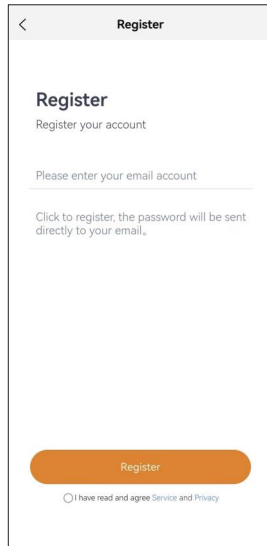
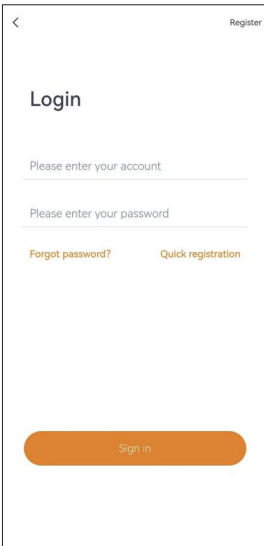

5. User is able to add new device by Scanning QR Code or entering device number.

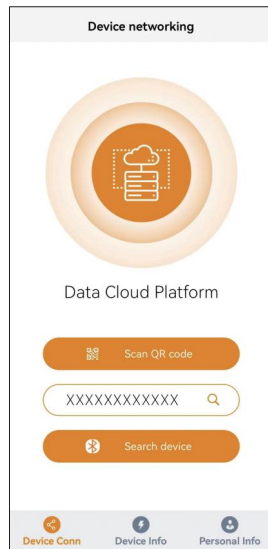
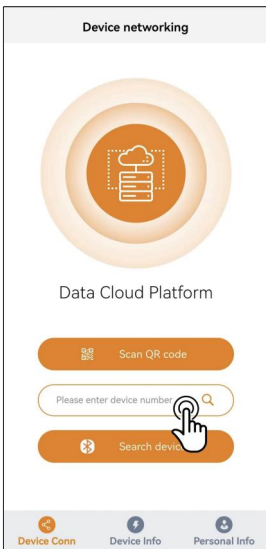
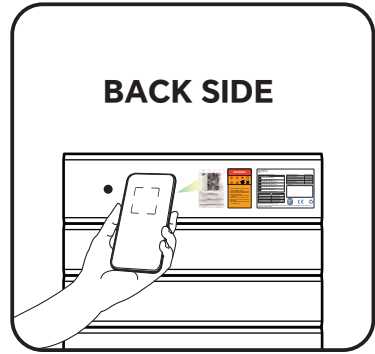
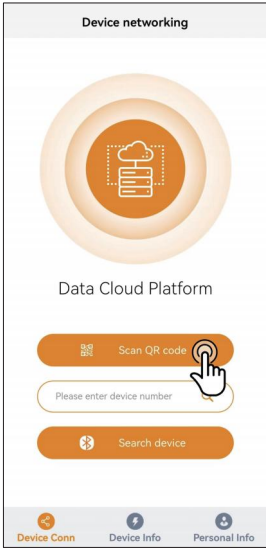

6. Wifi configuration: click Wifi Config <- Add manually.

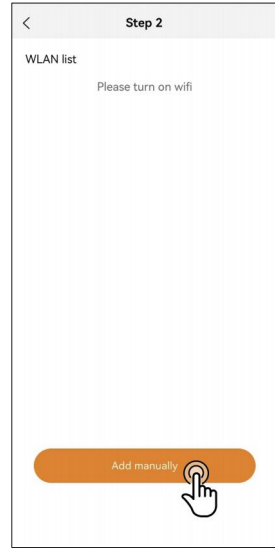
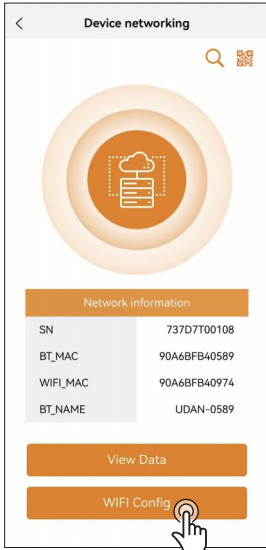

7. Type in Wifi password and wait until the process complete.

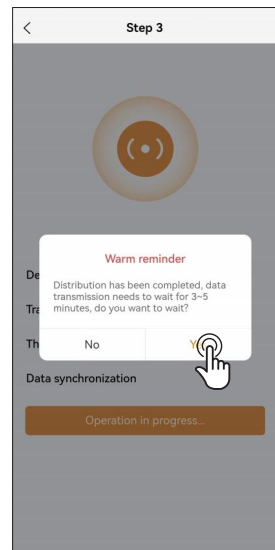
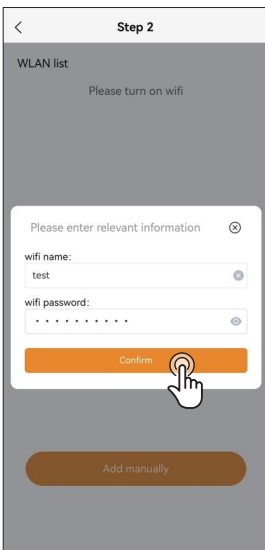

8. Connection successfully.

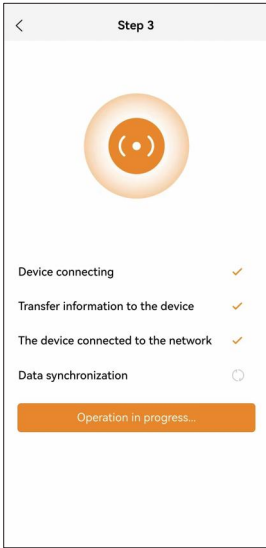

6 Maintenance

- If the battery is not in use, it is necessary to fully charge the battery every 3 months and discharge it to 25% to 50%
- Check the wall hangers every 6 months for looseness and tighten them if they are.
- Check the shell every 6 months for damage, if so, repaint or contact the after-sales service center.
- Check the exposed cable for wear every 6 months. If so, replace the cable or contact the after-sales service center.
- Every six months, check whether there is debris accumulation around the battery. If so, clean it up to avoid affecting the heat dissipation of the battery.
- Check once every 6 months for water or pests to avoid long-term intrusion of the battery.

WARNING!

- If you find the problem that may affect the battery or energy storage inverter system, please contact the after-sales personnel in time, prohibit private dismantling!
- If it is found that the copper wire inside the conductive wire is exposed, the high pressure is dangerous, do not touch! Please contact after-sales personnel, prohibit private disassembly!
- If there are other emergencies, please contact the first time after-sales staff, after-sales staff under the guidance of the operation, or waiting for after-sales staff on-site operation! Do not operate without permission!



 Tel: +86-574-65292531

 Website: www.gs-ess.com

 Email: service@gsmarte.com

 Address: 2 Xingke West Road, Meiqiao Industrial Zone, Meilin Street, Ninghai County, Ningbo City, Zhejiang Province, China